

New Collection  
2021

ES

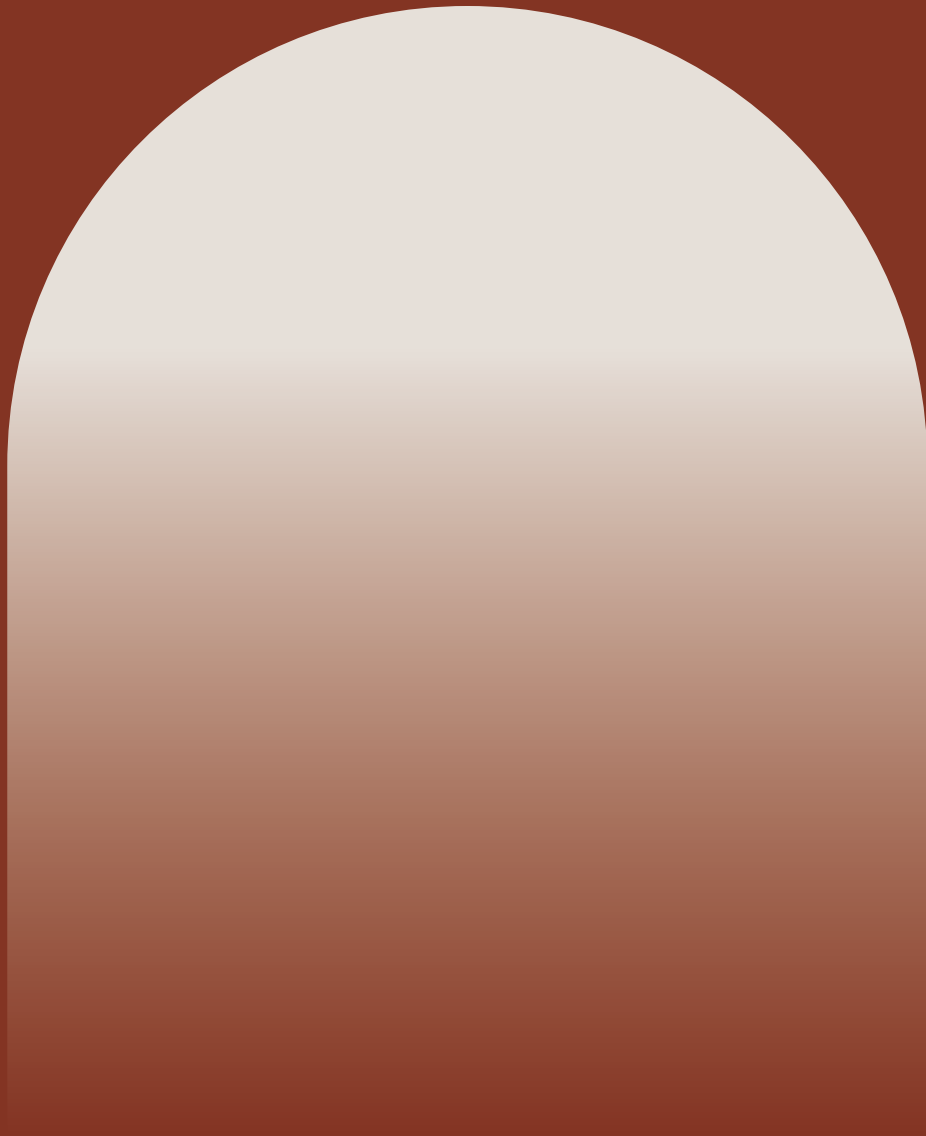



## New Collection 2021

Os presentamos la colección de mobiliario contemporáneo de Ofitres. Una colección que se ha creado cuidadosamente, pieza a pieza, con una enorme atención al detalle.

Nuestro objetivo es hacer muebles que nos despierten los sentidos, armonicen los espacios y perduren en el tiempo.

Tres colecciones, Hat; unos pufs con un sinfín de posibilidades, Tono; fina y singular estructura que es protagonista en un sistema de almacenaje, bancadas y escritorios. Finalmente, la colección de mesas Downtown. Todos los muebles de este catálogo están pensados para equipar desde un espacio de trabajo a un exclusivo hogar.

Han sido meses explorado formas, texturas y colores, con el gran equipo de la Mamba, hasta conseguir esta colección innovadora y de alto contenido en diseño.

Esperamos que sea de su agrado el nuevo ADN de Ofitres.



## ÍNDICE

<b>Hat</b> Poufs	8
<b>Tono</b> Bancada	20
<b>Tono</b> Armarios	30
<b>Tono</b> Escritorio	40
<b>Levels</b> Mesas auxiliares	48
<b>Acabados</b>	54

# HAT

*Poufs | Diseñado por La Mamba*



La colección de poufs *Hat* ayudan a optimizar espacios abiertos, creando zonas acogedoras y versátiles. *Hat* es una colección creada para la colaboración y las reuniones sociales. Diseñada con líneas suaves y atención a los detalles, aporta calidez al entorno, ofreciendo una comodidad accesible para las necesidades cambiantes.







↑ HAT PUD150, PUD45 y PUD100 | Composición poufs con  
mesa LEVEL D120  
→ HAT PUD100-T30, PUD45, PUD150-T40 y PUD100

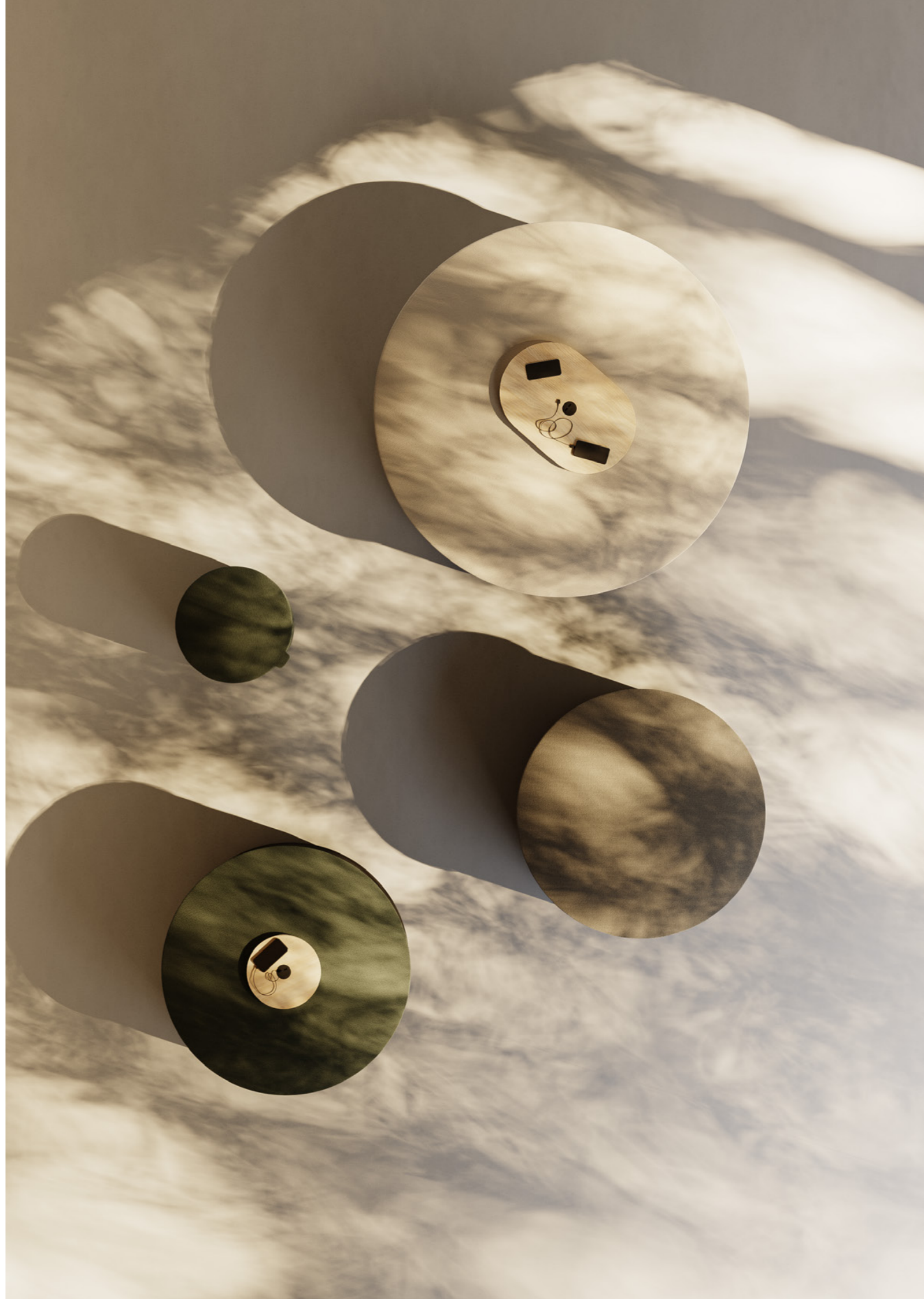



↶ HAT | Composición poufs con mesas **LEVELS**  
↑ HAT **PU6565, PU11065 y PU16065** | Composición poufs  
rectangulares  
↷ HAT | Composición poufs con mesas **LEVELS**







↖ ↑ **HAT PU16065D** | Pouf con doble asiento y respaldo

**PUD45**

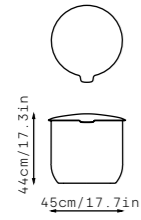

**PUD100**

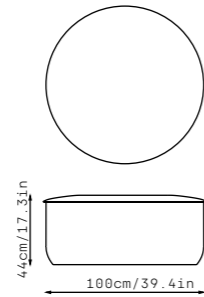

**PUD150**

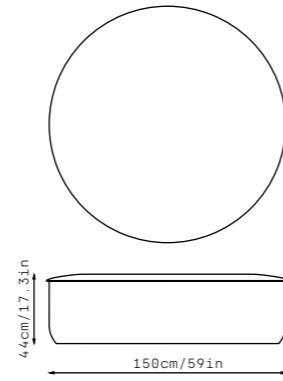

**PU6565**

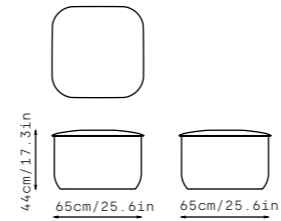

**PU11065**

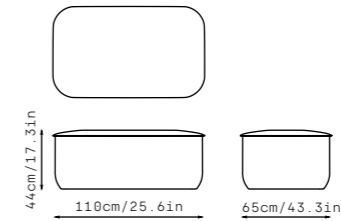

**PU16065**

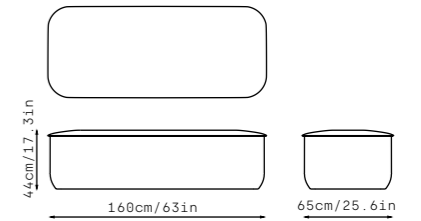

**PUD100 - T30**

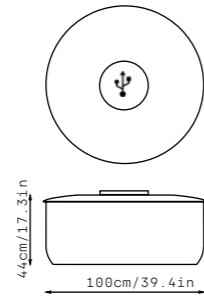

**PUD150 - T30**

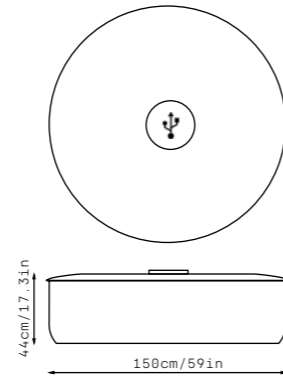

**PU11065R**

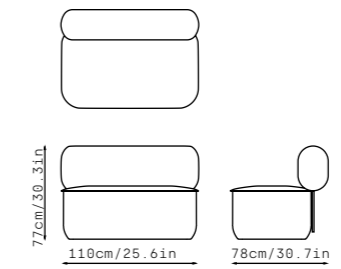

**PU16065R**

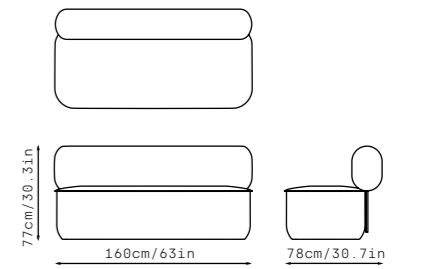

**PUD150 - T40**

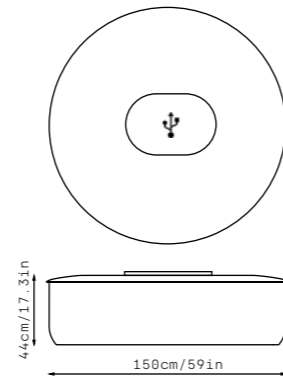

**PU11065D**

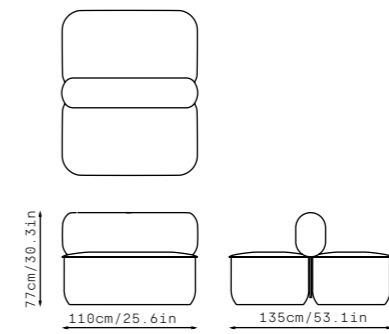

**PU16065D**

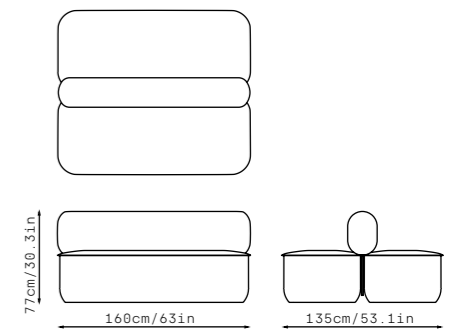

# TONO

*Bancadas | Diseñado por La Mamba*



El nuevo sistema de bancadas Tono ofrece una colección modular de asientos compuesta por módulos de 2 y 3 plazas. Diferentes brazos, asientos y mesas permitirán realizar miles de combinaciones. Un programa pensado tanto para espacios abiertos, donde crear grandes composiciones, como para espacios pequeños donde crear cuidados lugares de descanso



HALL



↖ **TONO** | Composición de bancadas con  
mesas **LEVELS**  
↑ **TONO** | Composición de banco de 3 plazas  
con mesa **LEVEL**



OFFICE



TONO BI1

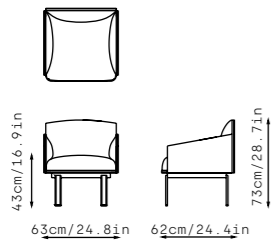

TONO BR1

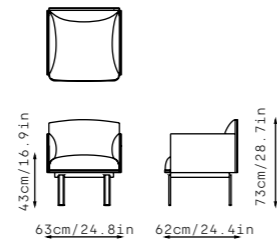

TONO SI2

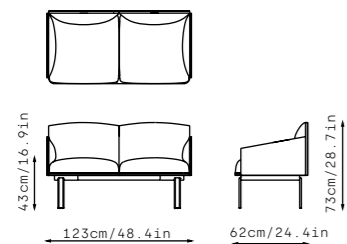

TONO SR2

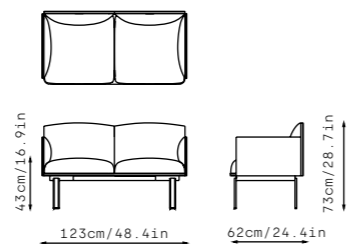

TONO SI3

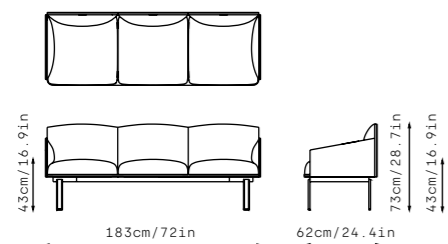

TONO SR3

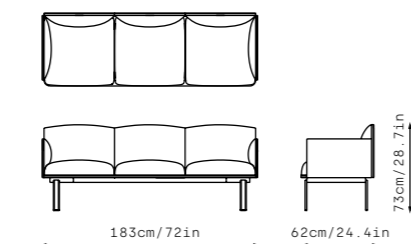

TONO SI4

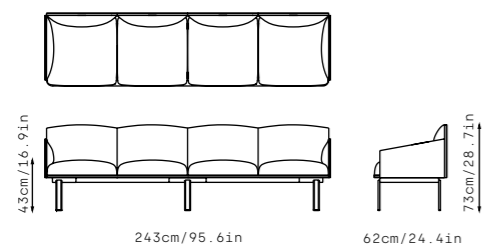

TONO SR4

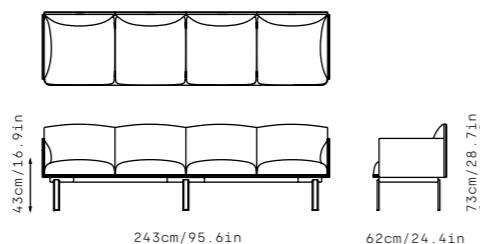

TONO SI5

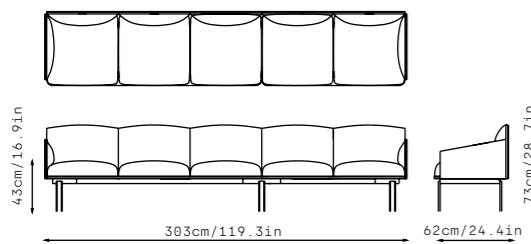

TONO SR5

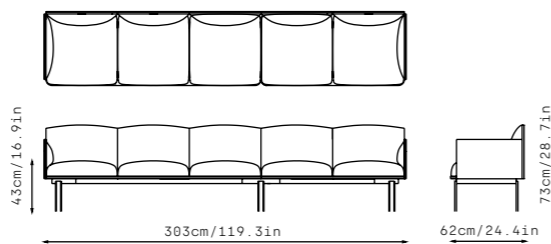

COMPOSICIONES | Ejemplos

COMP. 01

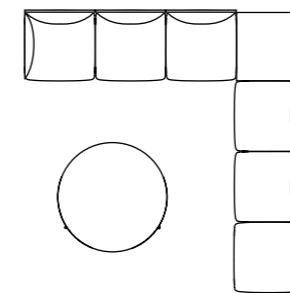

COMP. 02

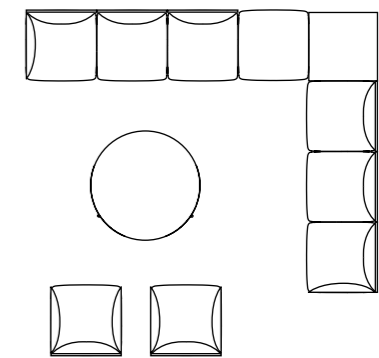

COMP. 03

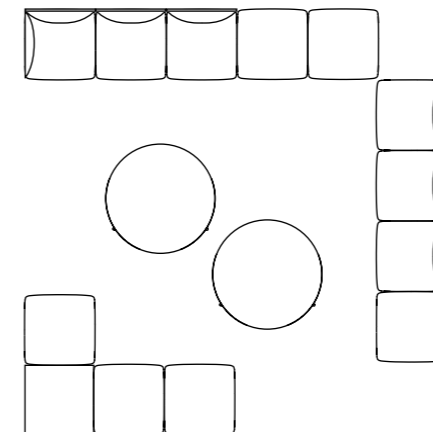

COMP. 04

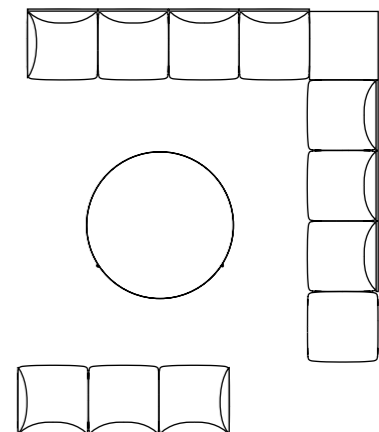

COMP. 05

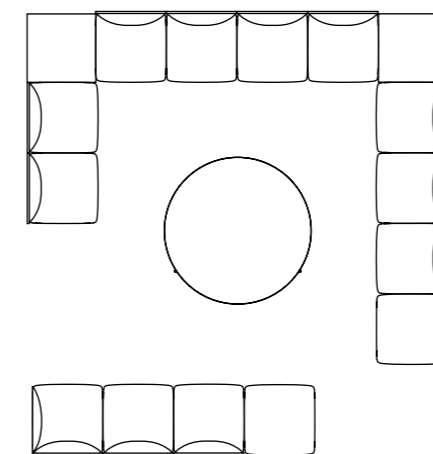

COMP. 06

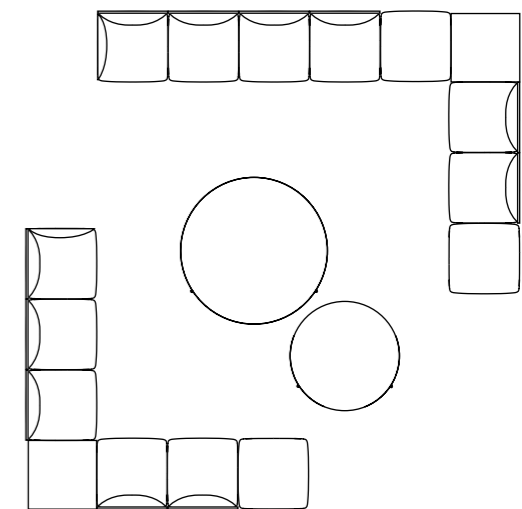

# TONO

*Almacenaje | Diseñado por La Mamba*



El sistema de almacenaje Tono representa la libertad de un programa muy completo de armarios abiertos y cerrados caracterizados por la ligereza de sus patas. Un programa pensado tanto para oficinas y espacios colectivos como para hogares.



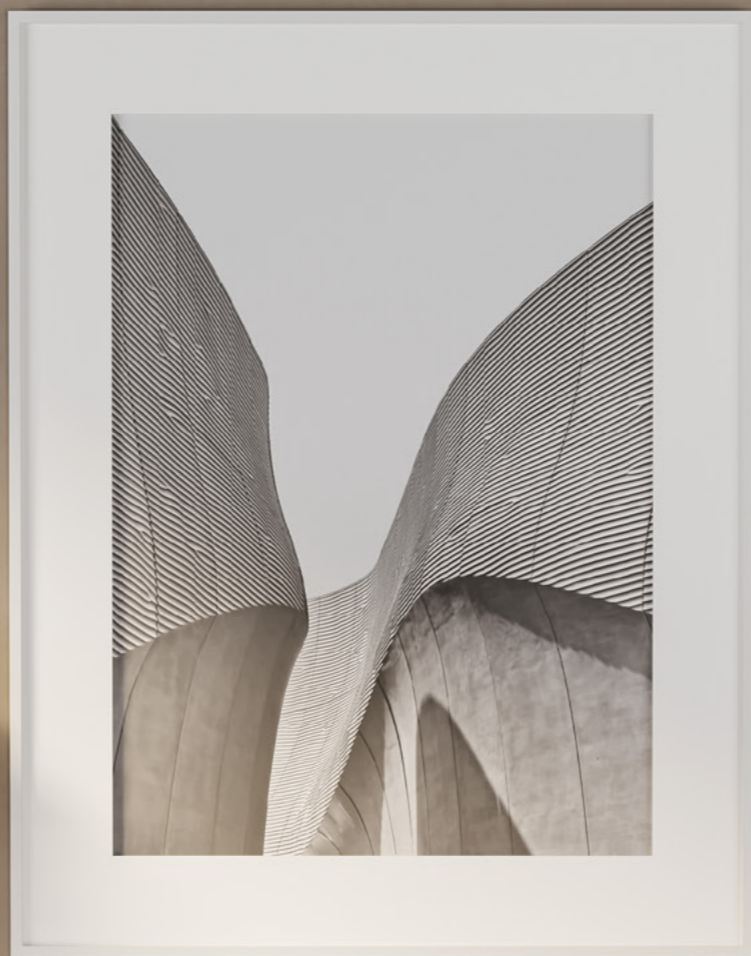

TONO | Detalle de armario  
MD7x78 acabado roble claro





↑ **TONO** | Detalle de armario MD7x78 acabado roble claro  
↙ **TONO** | Armario MD6x131 acabado melamina blanca

TONO MD2X78

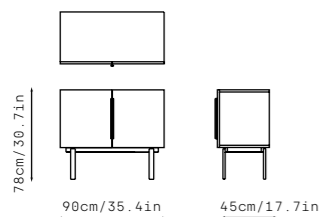

TONO MD3X78

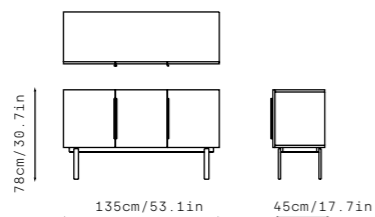

TONO MD4X78

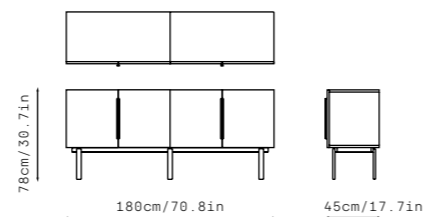

TONO MD5X78

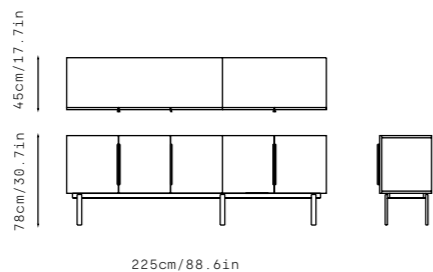

TONO MD6X78

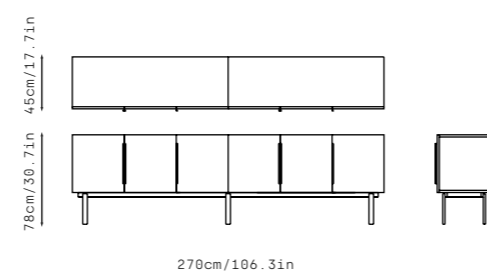

TONO MD2X98

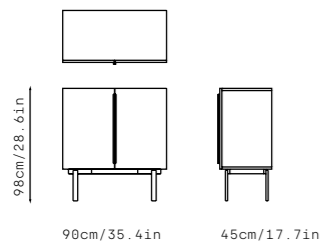

TONO MD2X131

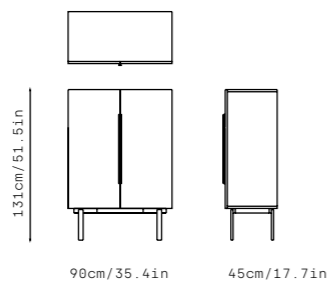

TONO MD2X171

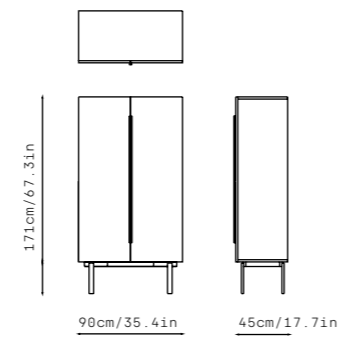

TONO MD2X191

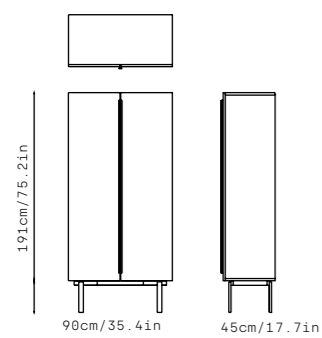

Ejemplo Composición

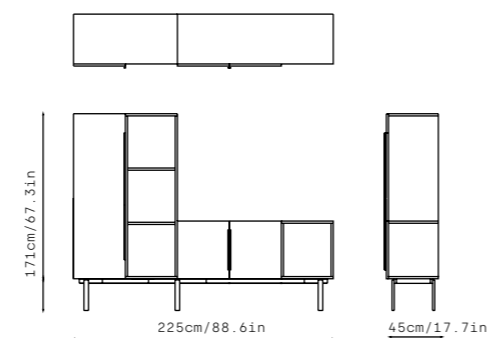

# TONO

*Escritorio | Diseñado por La Mamba*



La colección de escritorios *Tono* ofrece un producto destinado tanto para oficinas o consultas profesionales como para un espacio de trabajo dedicado en la casa. Su diseño caracterizado por los detalles de unión y sus patas ovaladas ofrece un escritorio ligero y resistente.







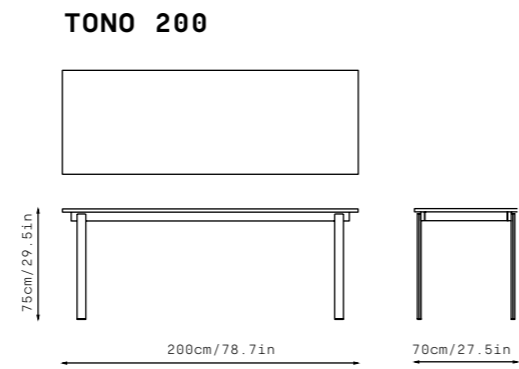
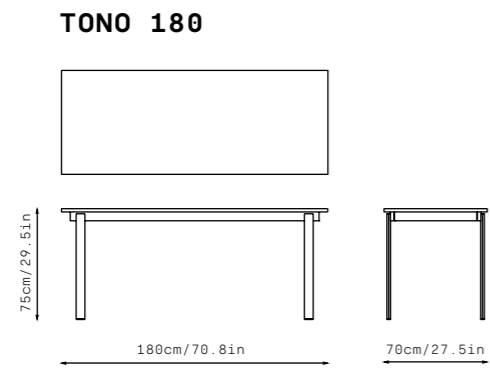
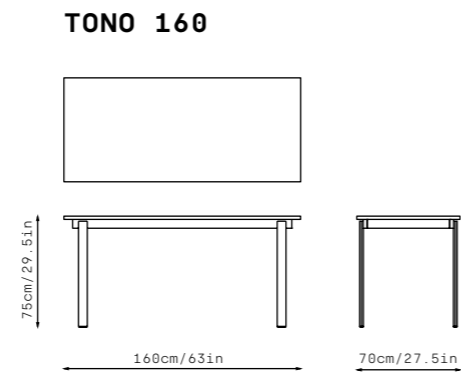
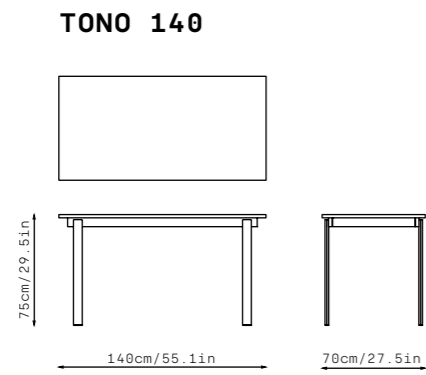
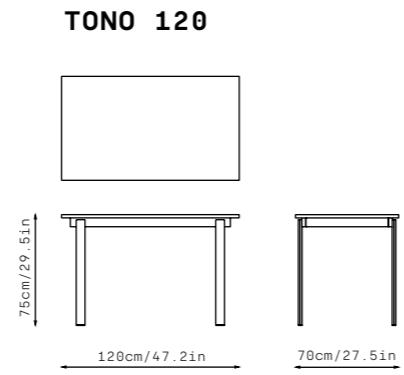
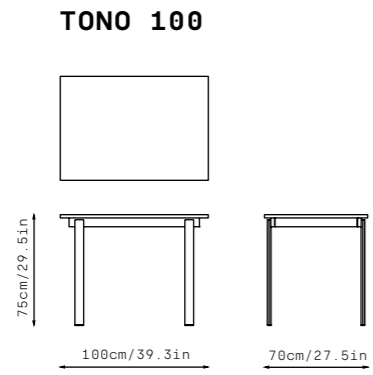

↘ TONO | Detalle escritorio  
↓ TONO 180 | Escritorio con silla D1





# LEVELS

*Mesas Auxiliares | Diseñado por La Mamba*



La colección de mesas *Levels* es el resultado de la armonía de las líneas suaves y las formas básicas. Un diseño esencial cargado de detalles que definen esta colección de mesas de centro y mesas auxiliares.





↖ LEVEL | Composición mesa LEVEL D120 y D85  
↑ LEVEL | Mesa LEVEL D120 y D35

**LEVEL D35\***

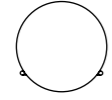
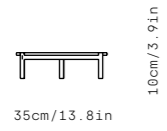

\*solo disponible acabado  
Nebraska y Haya Natural

**LEVEL D85**

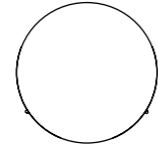
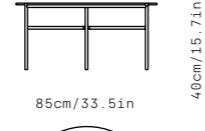

**LEVEL D5030**

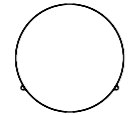
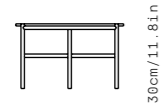

50cm/19.7in

**LEVEL D120**

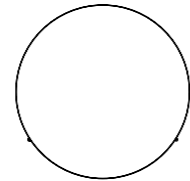
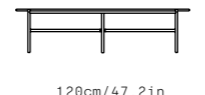

**LEVEL D5040**

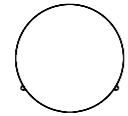
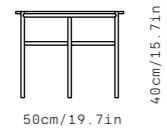

**LEVEL D5050**

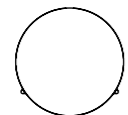
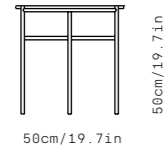

MELAMINA



Roble oscuro Nogal Nebraska Haya Natural Roble Claro Arce



Aluminio Gris Gris sombra Blanco

LUXE ALTO BRILLO



Azul Burdeos Ocre Cachemir Aluminio Blanco



Cuzco Oro Mrmar Blanco

LUXE SUPER MATE



Basalto Zenit Antracita Metal Blanco

ESTRUCTURA

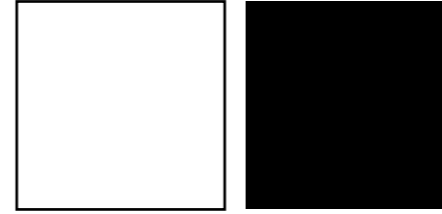

Blanco RAL 9003 Negro RAL 9005

TEXTILES

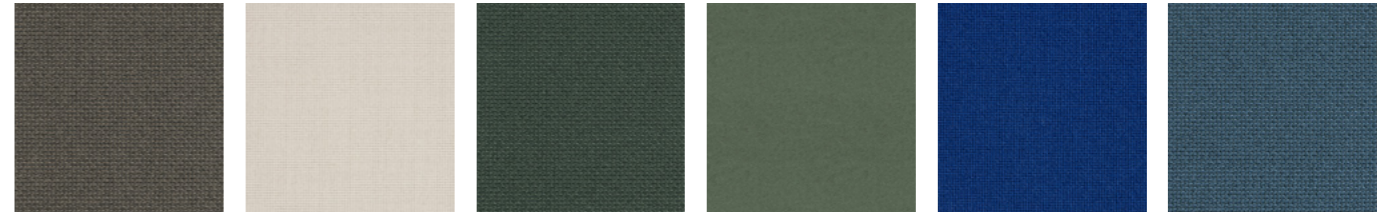

CURA 61169 GOUNI 61138 CURA 68182 SYNERGY 49 GOUNI 66137 CURA 66167

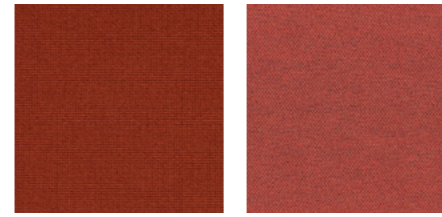

GOUNI 61144 ERA 29

Concepto y Dirección de arte /  
Concept and Art Direction  
La Mamba Studio

Diseño editorial y concepto /  
Editorial design and concept  
La Mamba Studio

Photography / Fotografía  
Renders  
La Mamba Studio

Copyright 2021 Ofitres. Grupo Alvic  
All rights reserved / Todos los derechos  
reservados.

Grupo Alvic FR Mobiliario S  
Tavèrnoles 5 Pol. Industrial Malloles  
08500 Vic (Barcelona)  
Spain

+34 93 889 25 02  
+34 93 889 11 57  
ofitres.ofi@grupoalvic.com

[www.ofitres.es](http://www.ofitres.es)



